



Specifications

Single ram Tilting Grading buckets

Tilting grading buckets are designed for the grading of banks etc.

They are built with a single large bore double acting ram for precise adjustments and stability. The ram is protected by a full coverage front plate

All buckets are fitted with a grease-able main hinge pin with replace-able hardened bushes in the main hinge boss

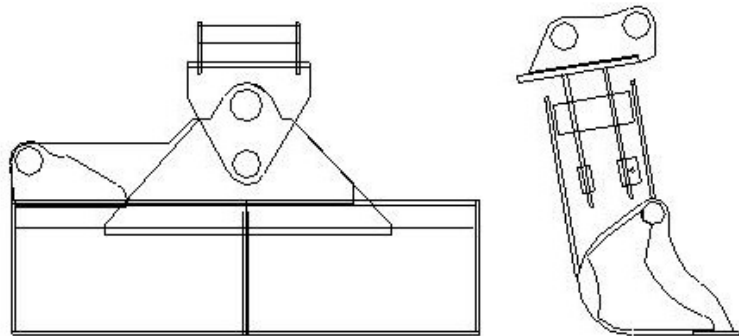

Designed to work off an auxiliary service and requires a flow rate of 50 to 70 litres a minute at a pressure of 2000 to 3000 psi

Machine	Part No.	No of rams	Width	Capacity	Ram Size
1 to 2 ton	213T/39	1	39"		1.5" Bore
2 to 4 ton	166T/48	1	48"	0.1	1.5" Bore
5 to 8 ton	003T/60	1	60"	0.16	3" bore
9 to 11 ton	150T/60	1	60"	0.23	3" bore
12 to 15 ton	114T/72	1	72"	0.39	4" Bore
16 to 18 ton	116T/72	1	72"	0.47	4" Bore
19 to 25 ton	116T/84	1	84"	0.55	4" bore

Capacities are in cubic metres SAE heaped.